



LITEGEAR

LITEBOX™ 2X8

FRAME ASSEMBLY INSTRUCTIONS

FOR LITEBOX™ 2X8, 1" DEEP AND LITEBOX™ 2X8, 6" DEEP
CINEMA/TELEVISION LED LIGHTING FRAME SYSTEM

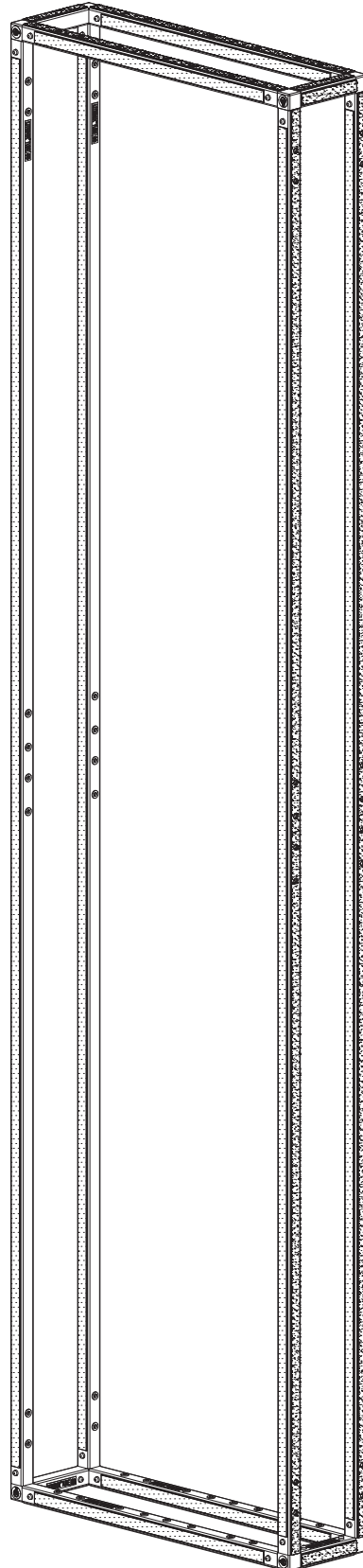
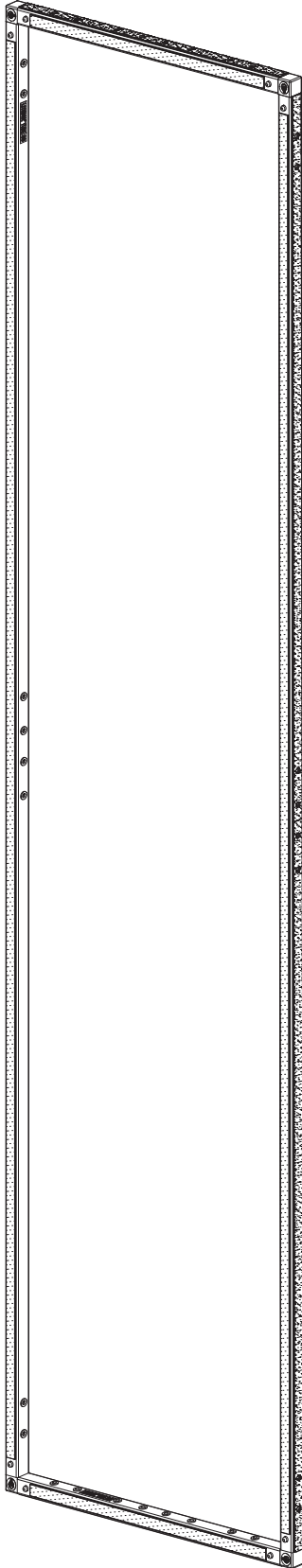

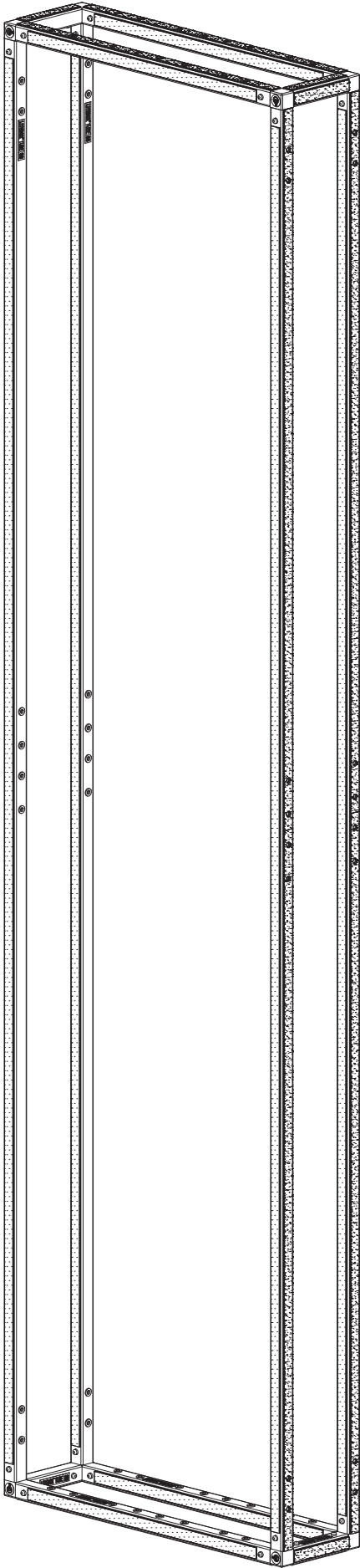

LITEBOX™ 2X8

LITEBOX™ 2X8, 6" DEEP
ASSEMBLY INSTRUCTIONS
for LTA-LITEBOX-2X8-BOX6

**PLEASE READ
INSTRUCTIONS
BEFORE ASSEMBLY**

COMPONENT LIST

ITEMS NEEDED

- 280-77 3-Way Corner - **White** decal (4 required)
- 280-78 3-Way Corner - **Yellow** decal (4 required)
- 280-7 LiteBox Tube - **06** decal (4 required)
- 280-9 LiteBox Tube - **24** decal (4 required)
- 280-11 LiteBox Tube - **96** decal (4 required)

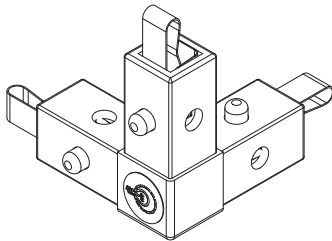

3-Way Corner
with **White** Decal
280-77 (Qty 4)

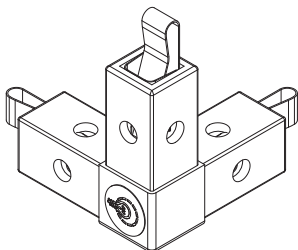

3-Way Corner
with **Yellow** Decal
280-78 (Qty 4)



LiteBox Tube
with **06** Decal
280-7 (Qty 4)

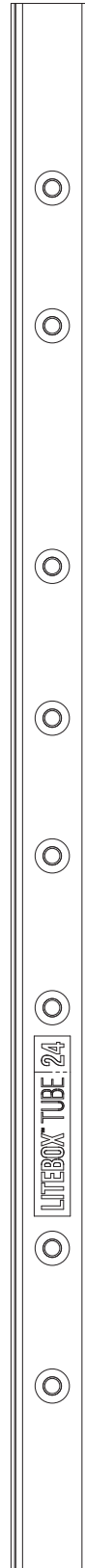

LiteBox Tube
with **24** Decal
280-9 (Qty 4)

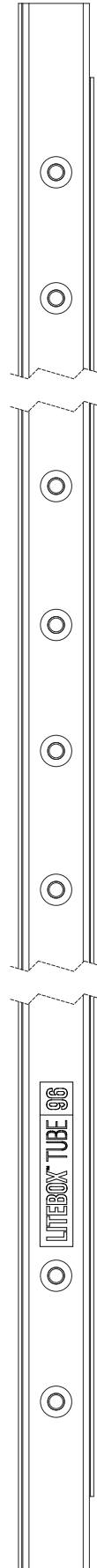

LiteBox Tube
with **96** Decal
280-11 (Qty 4)

OPERATING LITEBOX FITTINGS

1 Align pin to hole and slide fitting into tube.

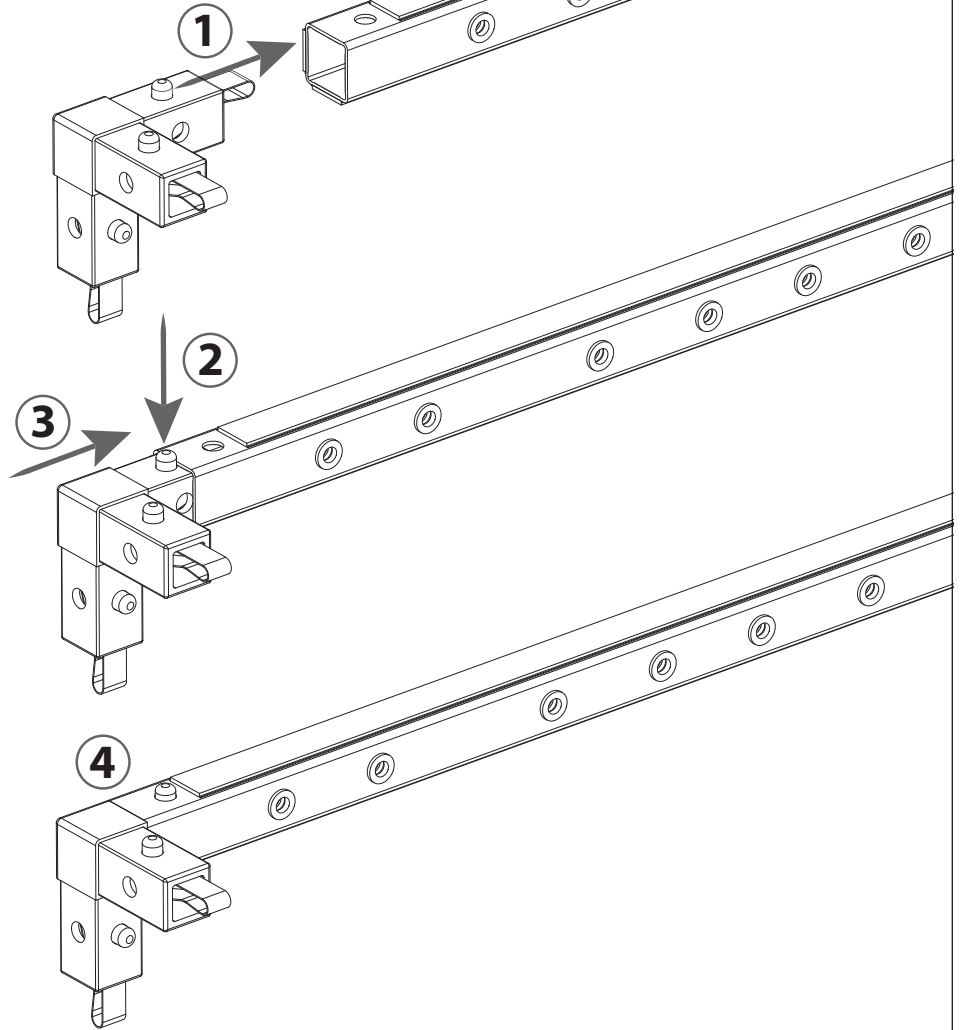

2 Depress pin.

3 Push in fitting until pin snaps in place.

4 Fitting fully installed.

REPLACING SNAP PINS

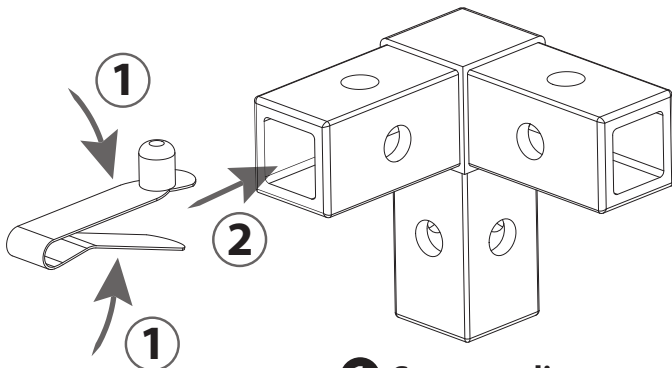

1 Squeeze clip.

2 Insert clip.

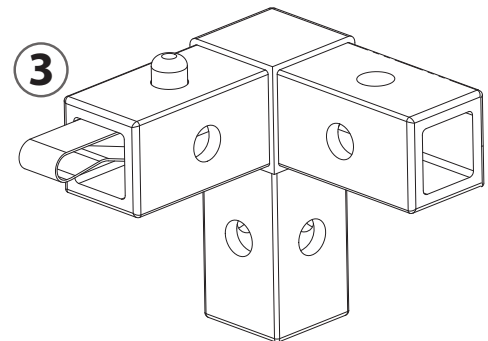

3 Clip fully installed.

ASSEMBLY - STEP 1 (2x)

ITEMS NEEDED

- 280-9 LiteBox Tube - **24** decal (2 required)
- 280-77 3-Way Corner - **White** decal (4 required)

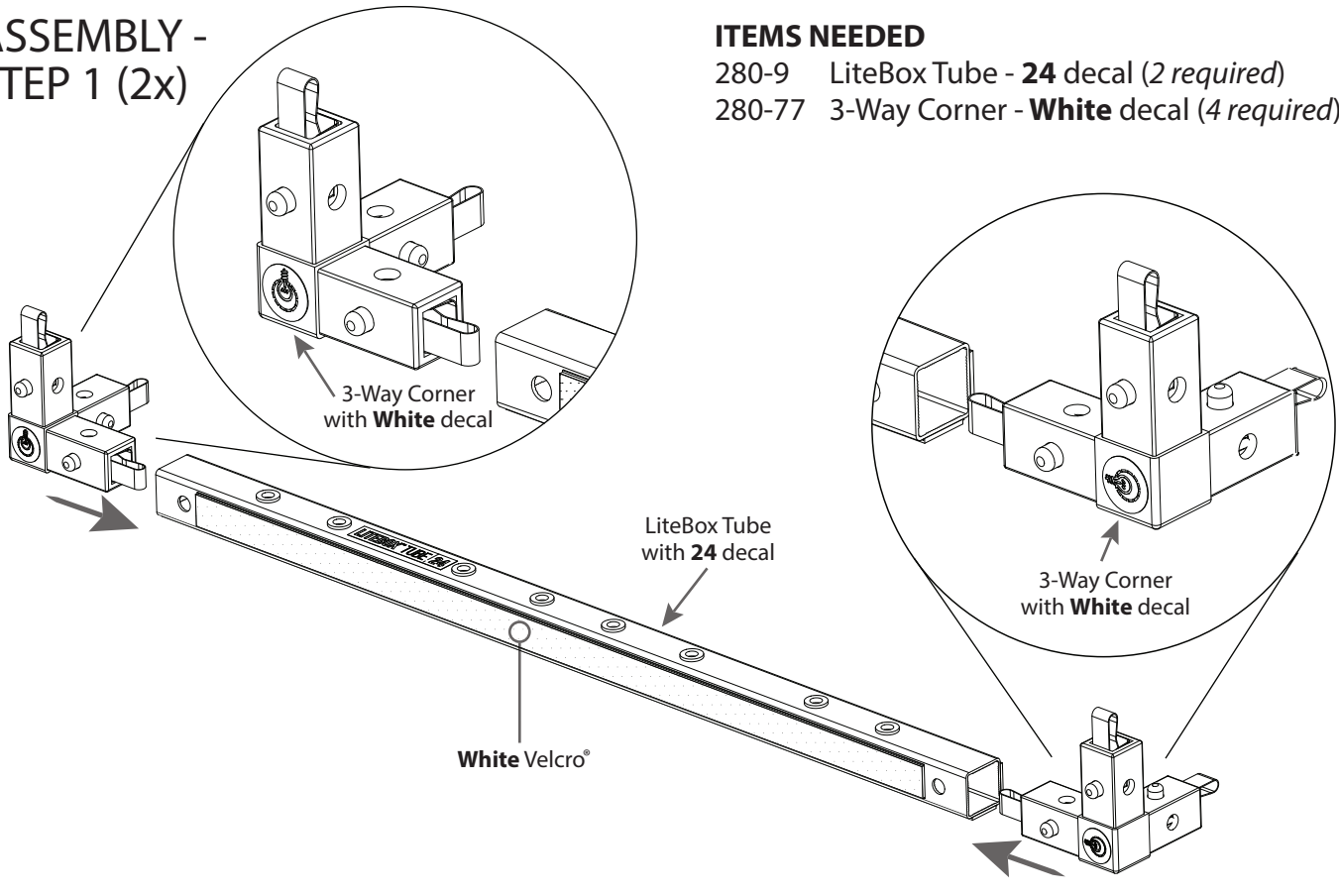

ASSEMBLY - STEP 2 (2x)

ITEMS NEEDED

- 280-9 LiteBox Tube - **24** decal (2 required)
- 280-78 3-Way Corner - **Yellow** decal (4 required)

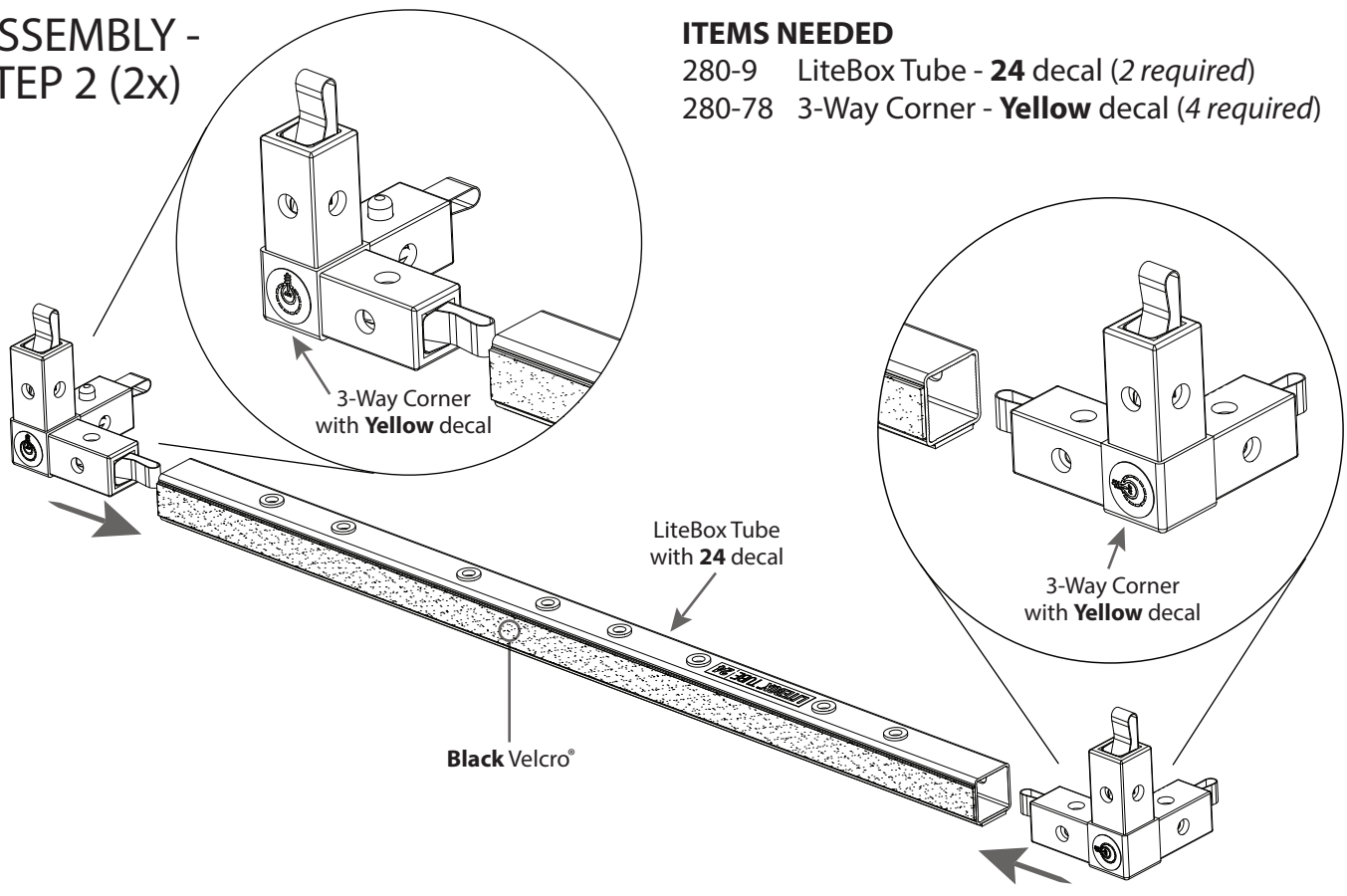

ASSEMBLY - STEP 3 (2x)

ITEMS NEEDED

Assembly from Step 1 (2 required)

280-7 LiteBox Tube - **06** decal (4 required)

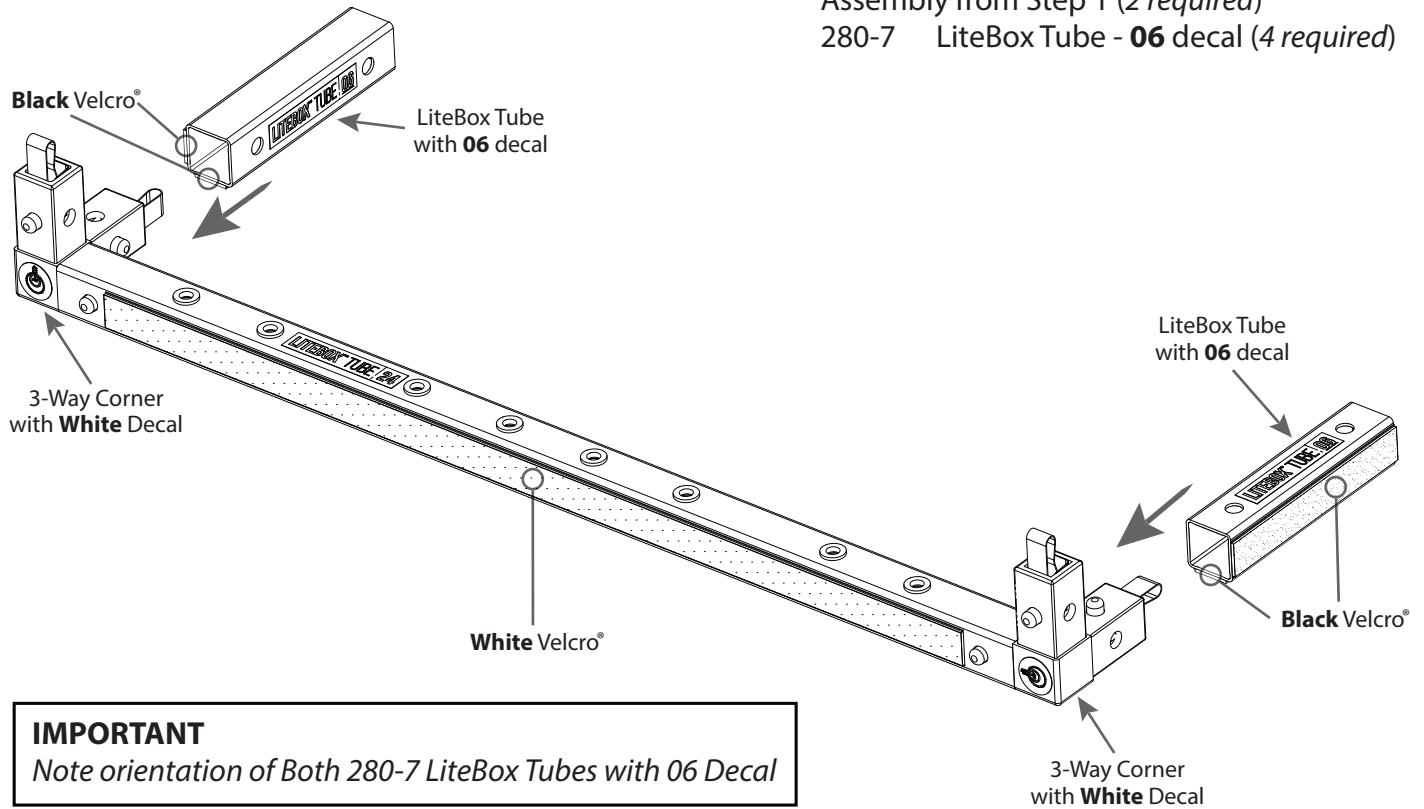

ASSEMBLY - STEP 4 (2x)

ITEMS NEEDED

Assembly from Step 2 (2 required)

Assembly from Step 3 (2 required)

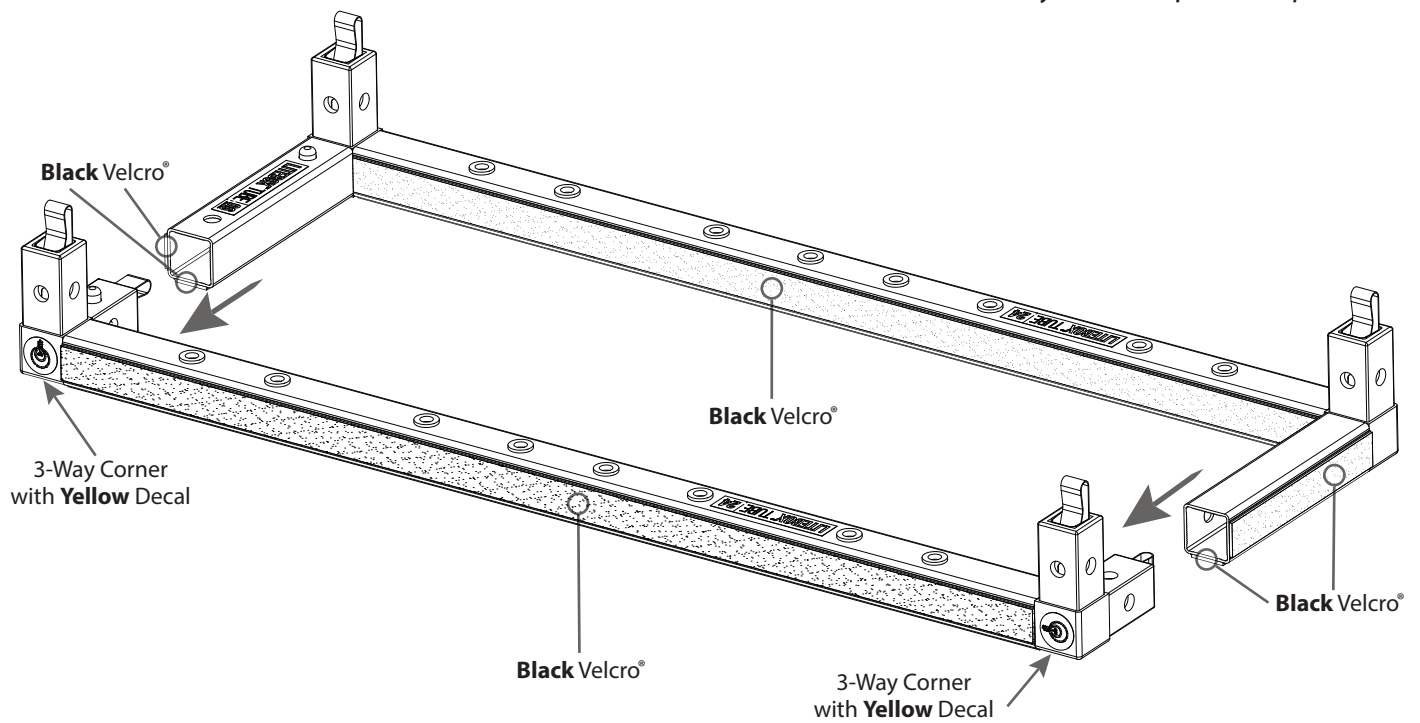

ASSEMBLY - STEP 5

ITEMS NEEDED

Assembly from Step 4 (1 required)

280-11 LiteBox Tube - **96** decal (4 required)

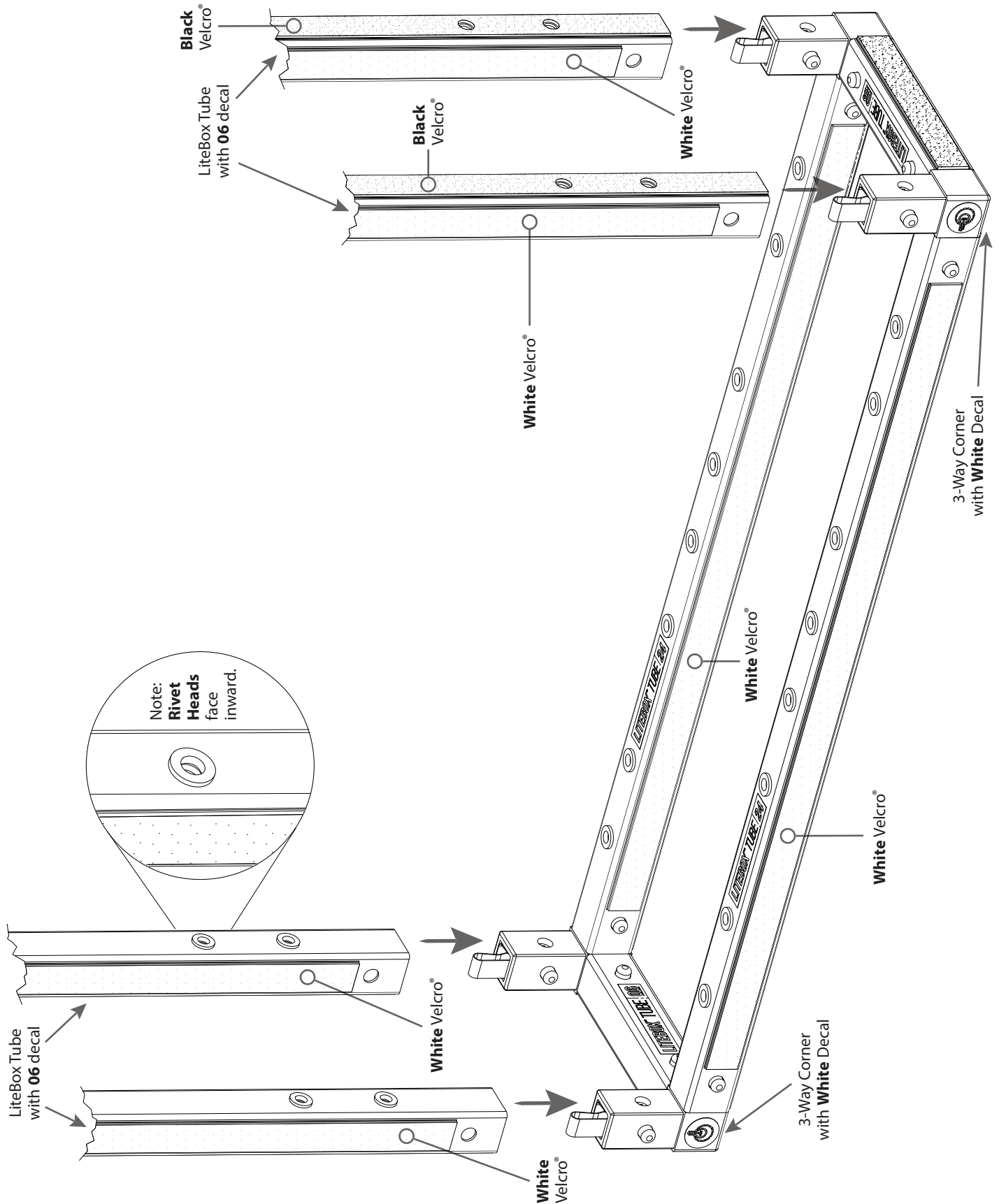

ASSEMBLY - STEP 6

ITEMS NEEDED

Assembly from Step 4 (1 required)

Assembly from Step 5 (1 required)

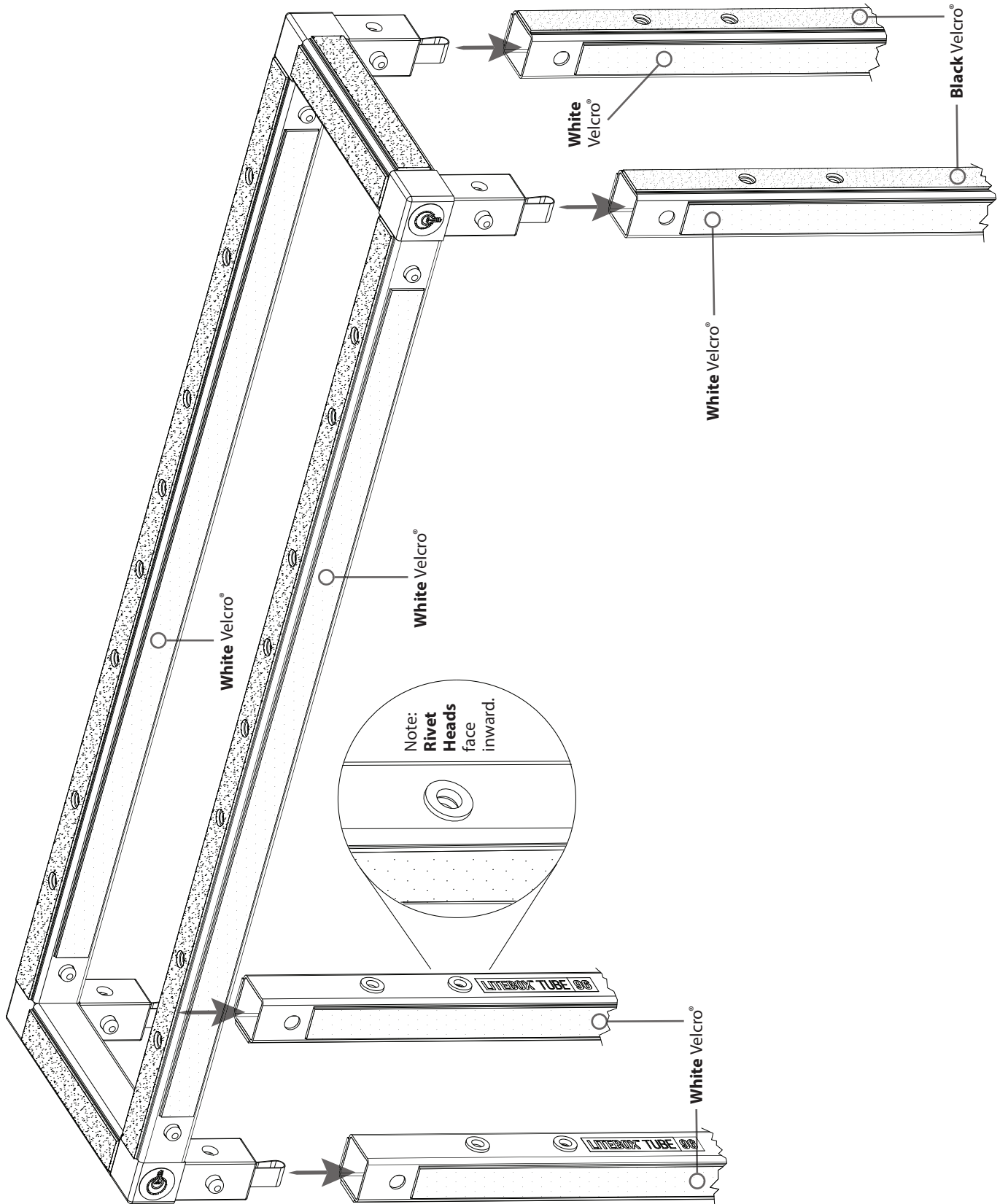

LITEBOX™ 2X8

LITEBOX™ 2X8, 1" DEEP
ASSEMBLY INSTRUCTIONS
for LTA-LITEBOX-2X8-BOX1

**PLEASE READ
INSTRUCTIONS
BEFORE ASSEMBLY**

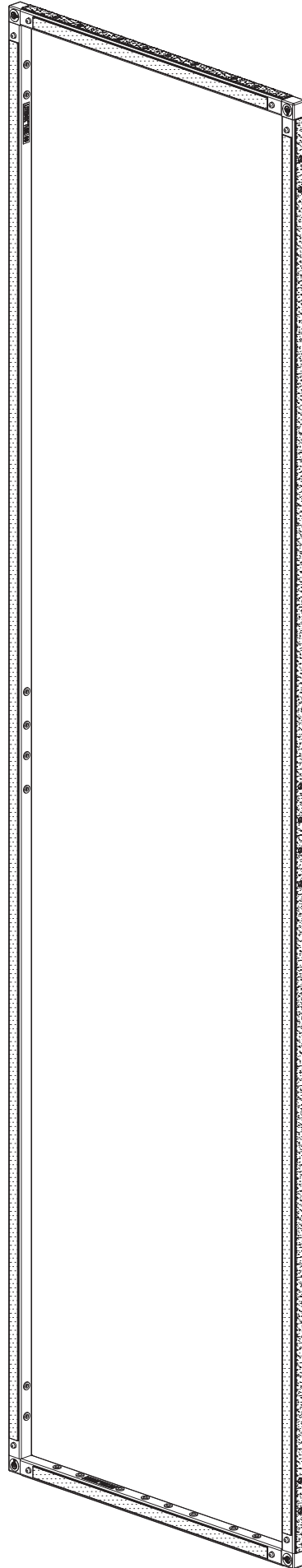

COMPONENT LIST

ITEMS NEEDED

280-79 2-Way Corner - **White** decal (4 required)

280-9 LiteBox Tube - **24** decal (2 required)

280-11 LiteBox Tube - **96** decal (2 required)

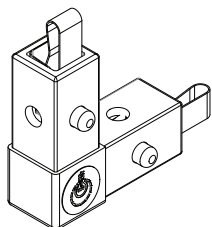

2-Way Corner
with **White** Decal
280-79 (Qty 4)

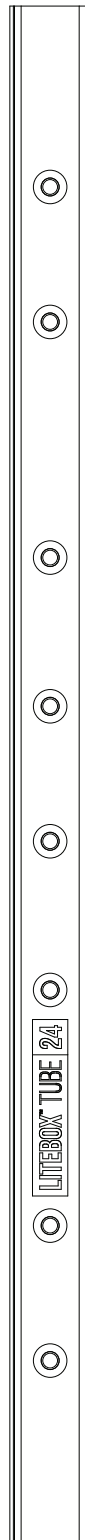

LiteBox Tube
with **24** Decal
280-9 (Qty 2)

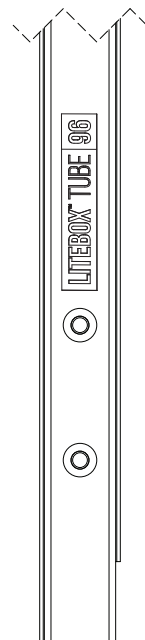
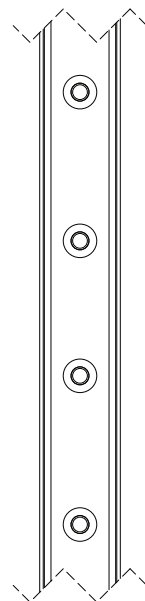
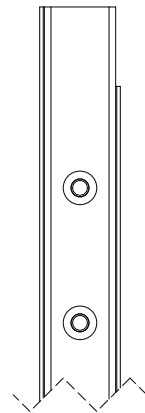

LiteBox Tube
with **96** Decal
280-11 (Qty 2)

OPERATING LITEBOX FITTINGS

1 Align pin to hole and slide fitting into tube.

2 Depress pin.

3 Push in fitting until pin snaps in place.

4 Fitting fully installed.

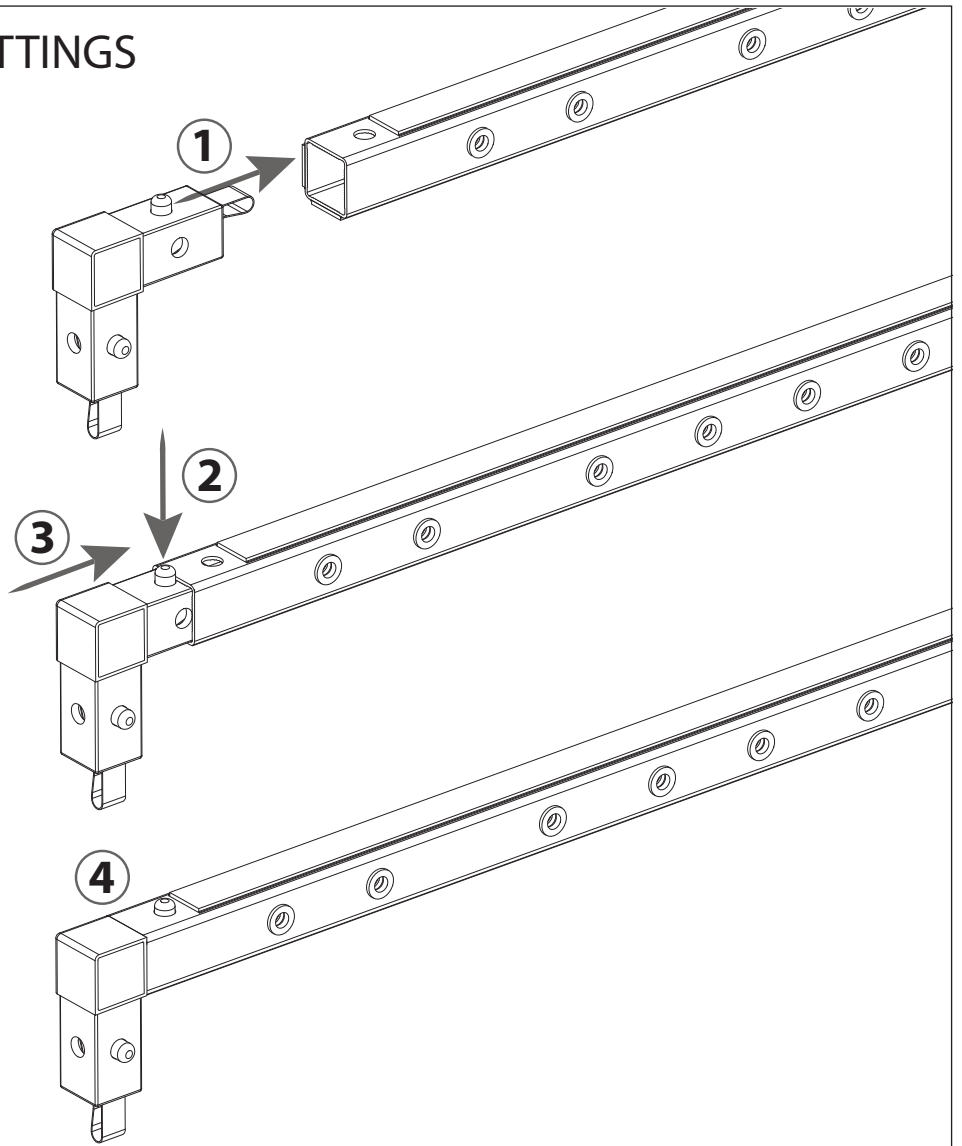

REPLACING SNAP PINS

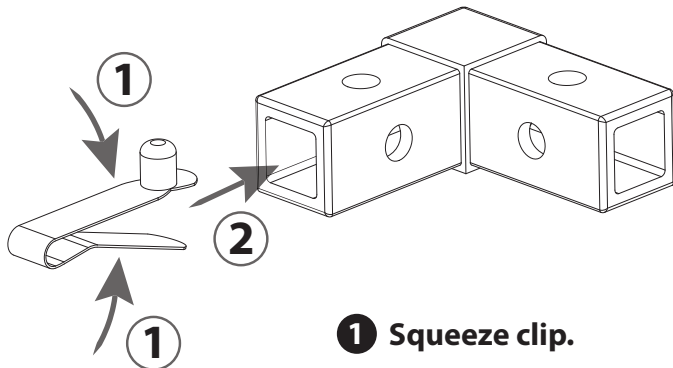

1 Squeeze clip.

2 Insert clip.

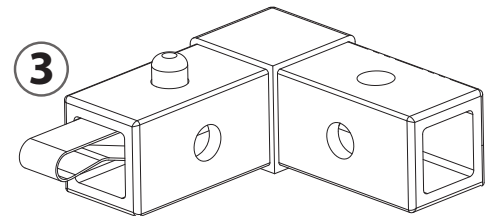

3 Clip fully installed.

ASSEMBLY - STEP 1

ITEMS NEEDED

- 280-9 LiteBox Tube - **24** decal (1 required)
- 280-79 2-Way Corner - **White** decal (2 required)

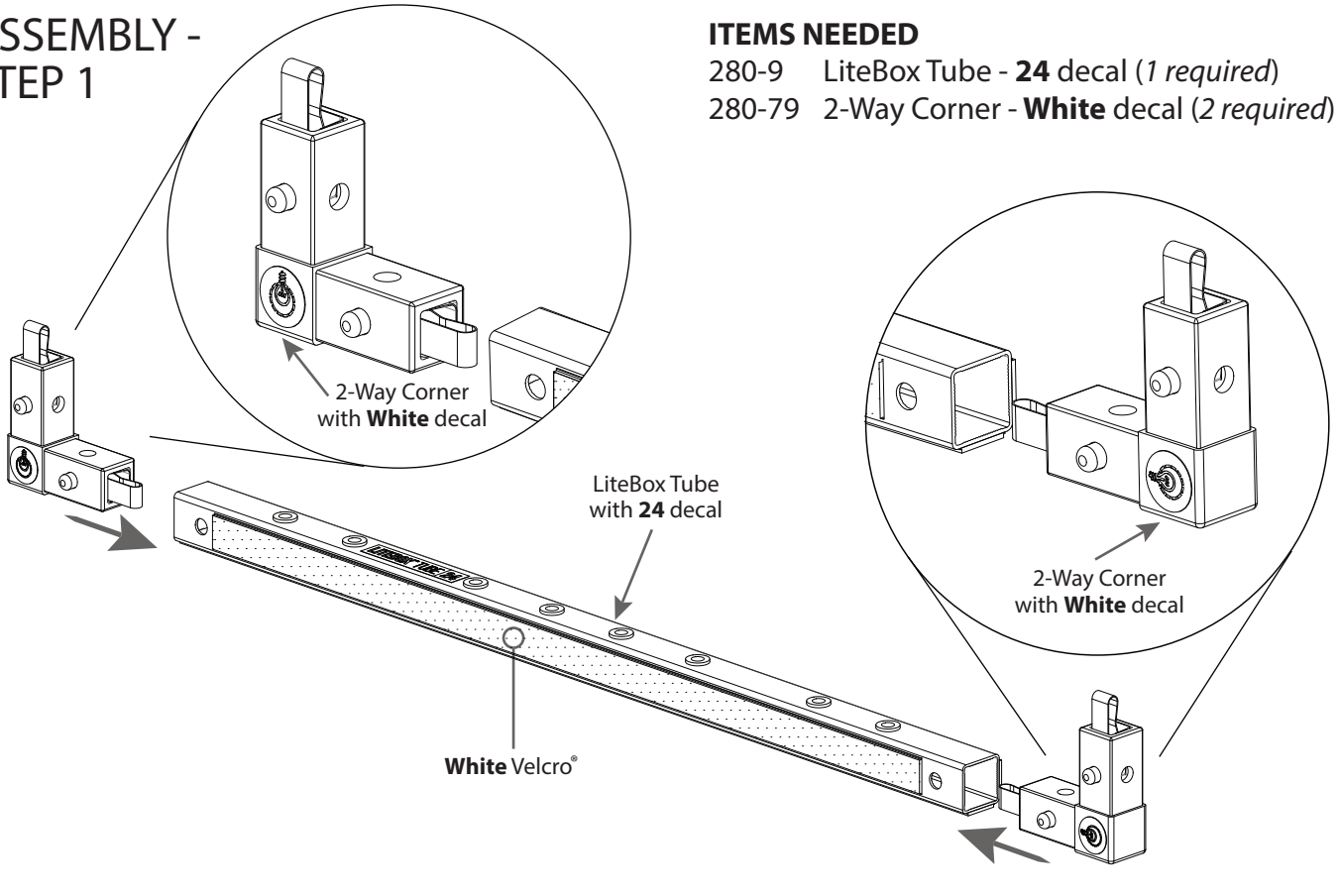

ASSEMBLY - STEP 2

ITEMS NEEDED

- 280-9 LiteBox Tube - **24** decal (1 required)
- 280-79 2-Way Corner - **White** decal (2 required)

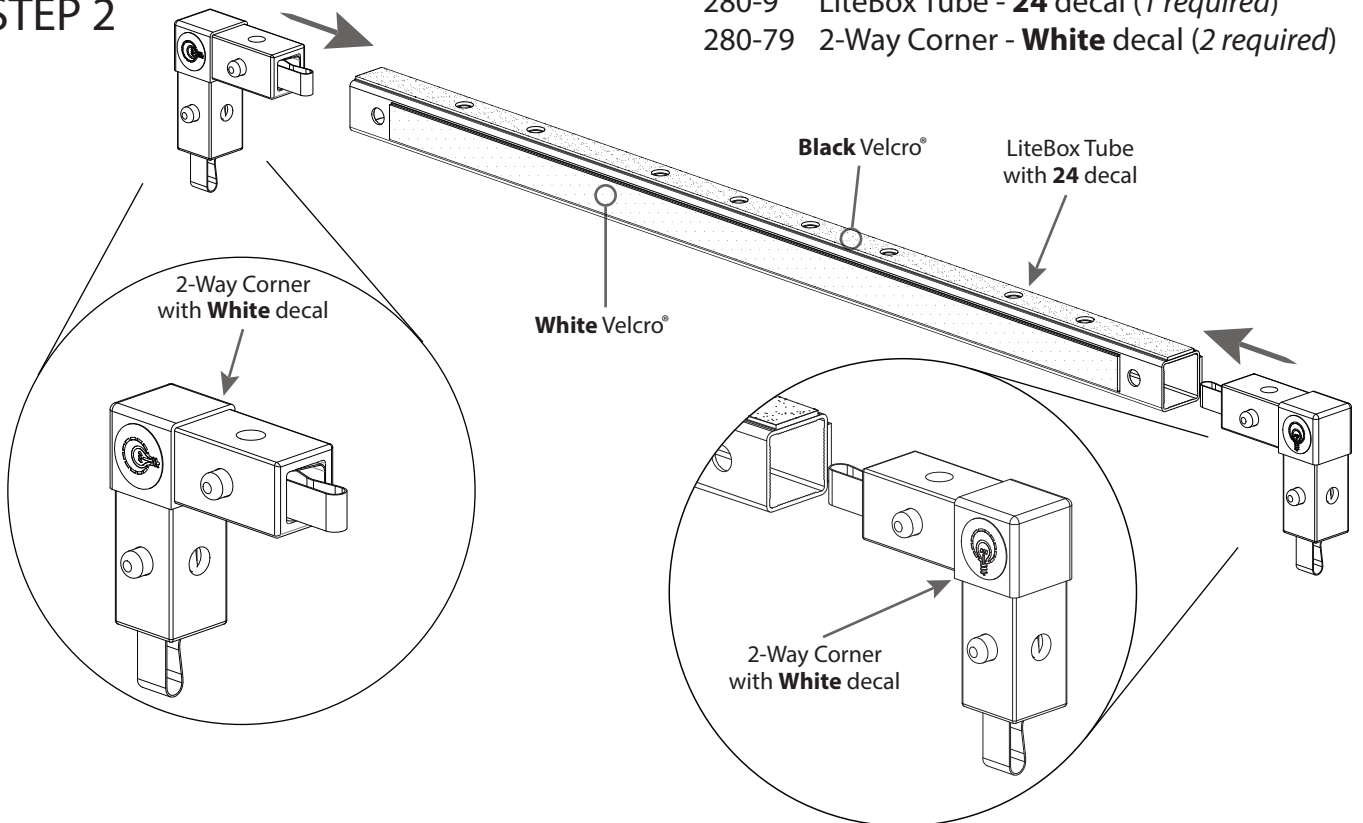

ASSEMBLY - STEP 3

ITEMS NEEDED

Assembly from Step 1

280-11 LiteBox Tube - **96** decal (2 required)

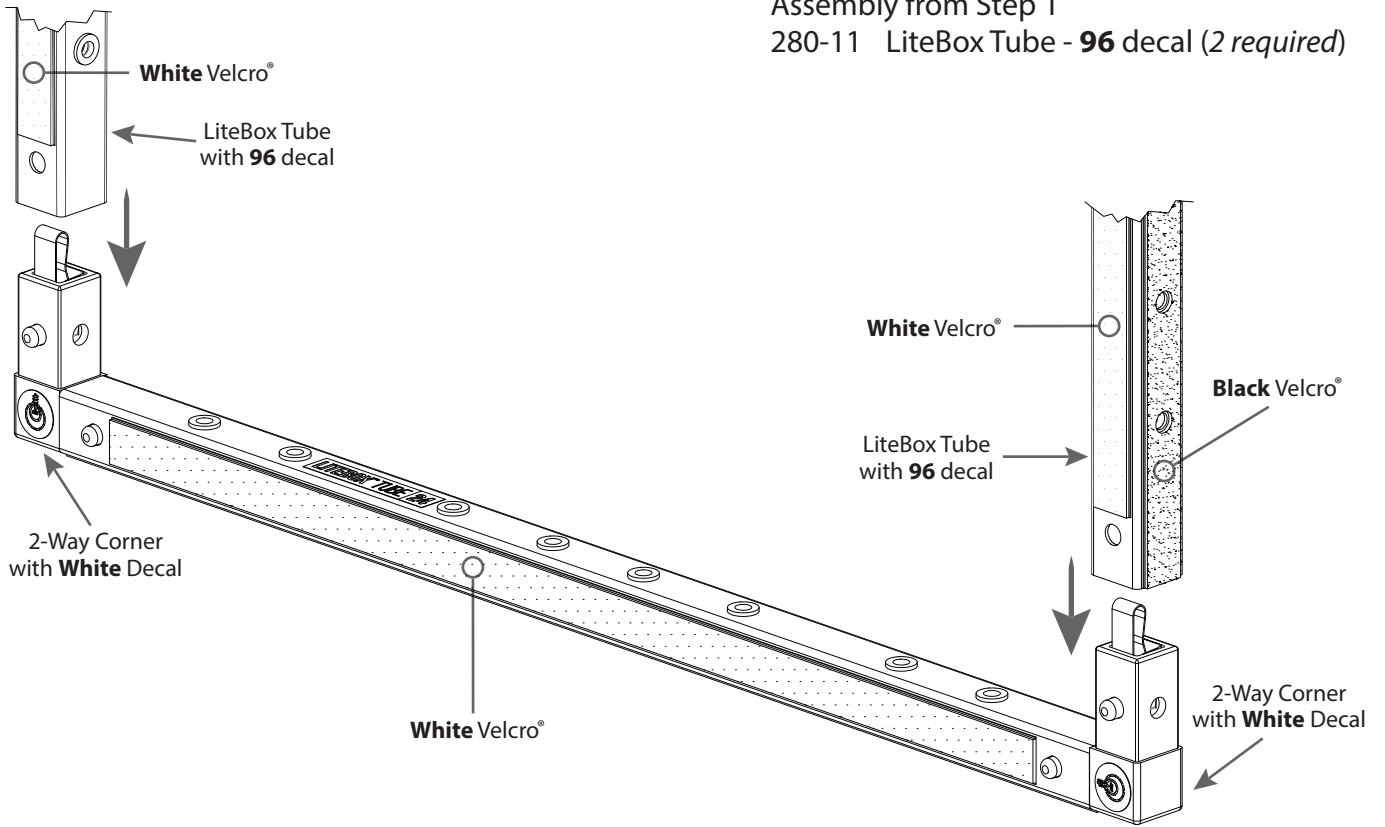

ASSEMBLY - STEP 4

ITEMS NEEDED

Assembly from Step 2

Assembly from Step 3

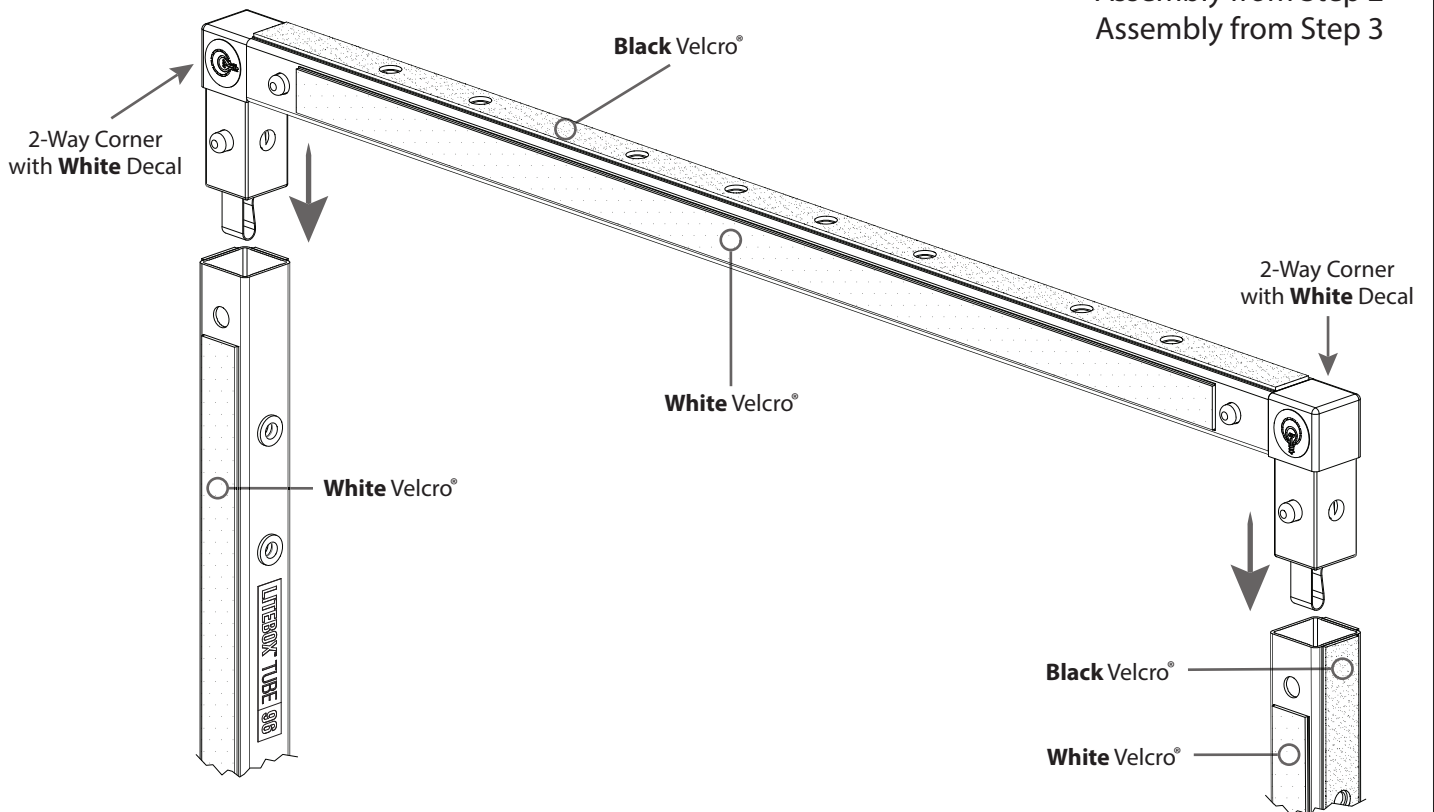

ASSEMBLY - COMPLETE

2-Way Corner
with **White** decal

White Velcro®

Black Velcro®

2-Way Corner
with **White** decal

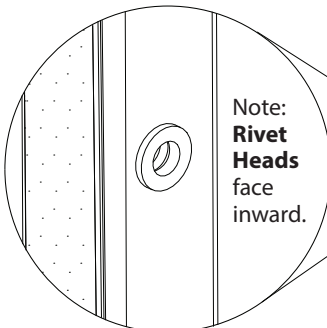

Black Velcro®

White Velcro®

2-Way Corner
with **White** decal

White Velcro®

2-Way Corner
with **White** decal

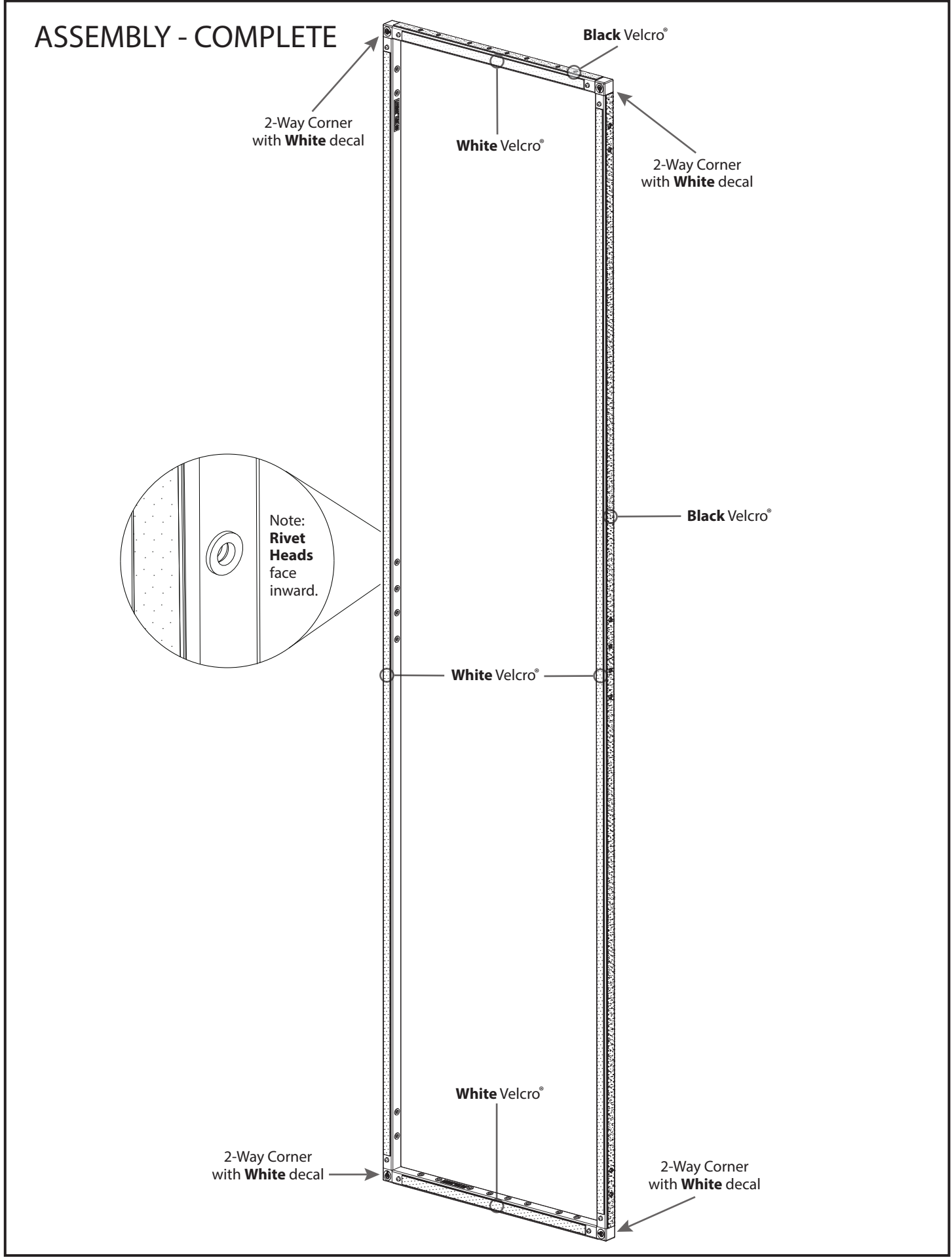



LITEGEAR, INC.

Tel: +1 818 358-8542 • Email: support@litegear.com • Web: litegear.com

© 2017 LITEGEAR, INC. All rights reserved. LiteRibbon® and FauxFlo® are registered trademarks of LiteGear, Inc.
© 2017 LITEGEAR, INC. All rights reserved. LiteGear™, LiteMat™, LiteDimmer™, LiteStix™, E-Control™, Hybrid™, Chroma™, Chroma-Correct™, LiteTile™, LiteBox™, LiteCloth™, CineHue™, CineMitter™, Cine Chroma™, Cine Series™, Studio Series™, Cine Hybrid™, Studio Hybrid™, FauxRes™, LiteEngine™, LiteNet™, LitePower™, LiteTenna™, QuickLinx™, TrueHybrid™, Vibrant Colors, Beautifully Saturated™, SkyMat™, Stardust™, and MapLite™ are trademarks of LiteGear, Inc.
VELCRO® is a registered trademark of Velcro BVBA